

AXS 215S: Continuous actuator for unit valves, with stroke indicator

How energy efficiency is improved

Reliable, precise actuation in efficient control systems

Features

- Fitted to the valve using no force thanks to the Low-Force-Locking (LFL) connector
- Fitted onto the valve with M30 × 1.5 thread, with automatic adjustment of closing dimension
- With 24 V~ thermal expansion element and accurate continuous input
- Large, visible position indicator
- NC “normally closed” and NO “normally open” versions
- Choice of direction of operation, 0(2)...10 V or 10...(2)0 V and split-range function, 0...4.5 V or 5.5...10 V
- Position monitoring with inductive, non-wearing sensor; does not require periodic recalibration
- Silent and maintenance-free
- Modular electrical plug connection (various cable lengths and types)
- Connected to valve with plastic bayonet connection
- Suitable for retrofitting existing installations without an adapter
- Fitting in any position, including upside down



AXS215SF122



Technical data

Power supply

Power supply	24 V~, ±20%, 50...60 Hz
Power consumption during operation	3 W
Starting power	Max. 5 W
Start-up current	220 mA
Stand-by current	Max. 6 mA
Operating current	Max. 90 mA

Parameters

Stroke	4.5/3 mm (can be selected)
Min. running time ¹⁾	Approx. 30 s/mm
Control signal 1	0...10 V, R _i ≥ 100 kΩ

Ambient conditions

Operating temperature at valve	100 °C
Storage and transport temperature	-25...70 °C
Admissible ambient temperature	0...50 °C
Admissible ambient humidity	< 85% rh, no condensation

Construction

Weight	0.21 kg
Housing	High-gloss surface (FV-0 as per EN 60707 and V-0 as per UL94), pure white (RAL 9010) or jet black (RAL 9005)
Housing material	Fire-retardant plastic
Power cable	Standard length 2 m, H03VV, PVC or halogen-free, 3 x 0.22 mm ² , white or black

Standards and directives

Type of protection	IP54 (EN 60529)
Protection class 24 V	III (EN 60730-1, EN 60730-2, EN 60730-14)

CE conformity according to	EMC Directive 2014/30/EU	EN 61000-6-1/EN 61000-6-2 EN 61000-6-3/EN 61000-6-4
----------------------------	--------------------------	--

¹⁾ The total time for 100% stroke is approx. 3.5...4.5 minutes (warm-up time) in the cold state or approx. 150 seconds in control mode without a dead time, i.e. in stand-by mode, add a dead time of approx. 110 seconds



Overview of types

i Closing force in combination with SAUTER valves

Type	Closing force	NC/NO
AXS215SF122	115 N	NC
AXS215SF122B	115 N	NC
AXS215SF222	110 N	NO
AXS215SF222B	110 N	NO

💡 AXS215SF122, AXS215SF222: White version, including M30 x 1.5 bayonet nut, cable 2 m, pack of one

💡 AXS215SF122B, AXS215SF222B: Black version, including M30 x 1.5 bayonet nut, cable 2 m, pack of one

Accessories

Connectors with continuous actuation (for 24 V AC version only)

Type	Description
0550423121	Continuous activation NC adjustable: 0(2)...10 / 10...0(2) V, split-range unit 0...4.5 V or 5.5...10 V, for 4.5 mm or 3 mm stroke, 2 m white cable, PVC 3 x 0.22 mm ²
0550423221	Continuous activation NO adjustable: 0(2)...10 / 10...0(2) V, split-range unit 0...4.5 V or 5.5...10 V, for 4.5 mm or 3 mm stroke, 2 m white cable, PVC 3 x 0.22 mm ²
0550423151	Continuous activation NC adjustable: 0(2)...10 / 10...0(2) V, split-range unit 0...4.5 V or 5.5...10 V, for 4.5 mm or 3 mm stroke, 5 m white cable, PVC 3 x 0.22 mm ²
0550423251	Continuous activation NO adjustable: 0(2)...10 / 10...0(2) V, split-range unit 0...4.5 V or 5.5...10 V, for 4.5 mm or 3 mm stroke, 5 m white cable, PVC 3 x 0.22 mm ²
0550423171	Continuous activation NC adjustable: 0(2)...10 / 10...0(2) V, split-range unit 0...4.5 V or 5.5...10 V, for 4.5 mm or 3 mm stroke, 7 m white cable, PVC 3 x 0.22 mm ²
0550423271	Continuous activation NO adjustable: 0(2)...10 / 10...0(2) V, split-range unit 0...4.5 V or 5.5...10 V, for 4.5 mm or 3 mm stroke, 7 m white cable, PVC 3 x 0.22 mm ²
0550423123	Continuous activation NC adjustable: 0(2)...10 / 10...0(2) V, split-range unit 0...4.5 V or 5.5...10 V, for 4.5 mm or 3 mm stroke, 2 m white halogen-free cable, 3 x 0.22 mm ²
0550423153	Continuous activation NC adjustable: 0(2)...10 / 10...0(2) V, split-range unit 0...4.5 V or 5.5...10 V, for 4.5 mm or 3 mm stroke, 5 m white halogen-free cable, 3 x 0.22 mm ²

Various accessories

Type	Description
0550240001	Removal-protection device for AXT/AXS211 (prevents the unauthorised removal of the plug and actuator)

Adapters & adapter sets

Type	Description
0550390101	Raised M28 x 1.5 bayonet nut (grey), with N-insert (normal, black) and S-insert (reduced, white), for all valves with M28 x 1.5 threads and angle valves or valves with measurement sockets; dimension of actuator 5 mm higher. Closing dimension depending on type of use: NC 4.5 mm to 18.5 mm and NO 8.5 mm to 22.5 mm, e.g. Pettinaroli
0550390201	Raised M30 x 1.0 bayonet nut (white), with N-insert (normal, black) and S-insert (reduced, white), for all valves with M30 x 1.0 threads and angle valves or valves of different manufacturers; dimension of actuator 5 mm higher. Closing dimension depending on type of use: NC 4.5 mm to 18.5 mm and NO 8.5 mm to 22.5 mm, e.g. Oventrop (up to 1997), Beulco (up to 2004)
0550393002	Adapter for fitting to Danfoss valves, type RAVL, 26 mm
0550393003	Adapter for fitting to Danfoss valves, type RAV, 34 mm
0550393004	Adapter for fitting to Danfoss valves, type RA 2000, 22 mm
0550394001	Adaptor for fitting to Giacomini valves, type R450, R452, R456 and range 60
0550399001	Adaptor set comprising: raised bayonet nut, black M30 x 1.5 (all manufacturers, M30 x 1.5); raised bayonet nut, grey M28 x 1.5 (all manufacturers, M28 x 1.5); raised bayonet nut, white M30 x 1.0 (e.g. Oventrop, Beulco); 2 x N-inserts (black) and 2 x S-inserts (white); Danfoss adaptor RA 2000 (Ø 22 mm); Giacomini adaptors

Description of operation

The actuator has an electrically heated expansion element protected against overload, which transfers its stroke directly to the attached valve. It operates noiselessly and is maintenance-free. If the heating element is turned on when it is cold (ambient temperature approx. 21 °C), the valve begins opening after a warming-up time of approx. 2.4 min, and after an additional period of approx. 2.7 min. it has carried out a stroke of 4.5 mm. When the actuator is controlling, it moves to the desired stroke position depending on control voltage y . An adjustment (heating up) of 1 mm is performed in approx. 30 s and the stroke is monitored by an inductive sensor. The closing operation is practically symmetri-

cal to the opening operation in terms of time; the expansion element cools down and the valve is closed by spring force.

Runtime behaviour

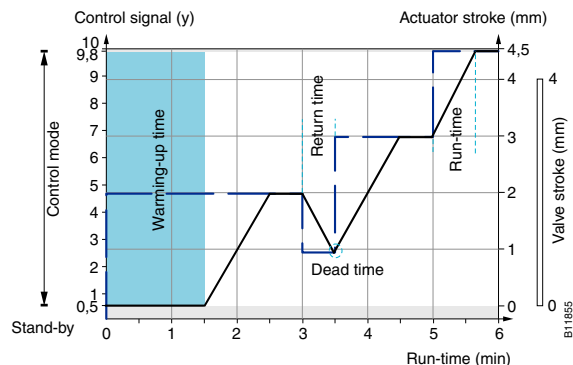

Intended use

This product is only suitable for the purpose intended by the manufacturer, as described in the “Description of operation” section.

All related product regulations must also be adhered to. Changing or converting the product is not admissible.

Stand-by mode

The actuator switches to the stand-by mode when the control voltage is less than 0.5 V for direction of operation 1 or greater than 9.5 V for direction of operation 2.

Running time (preparation)

When it is cold, the actuator requires a warming-up time of approx. 2.4 min. The same time is also required when the actuator has been in stand-by mode for over 6 min.

Running time (control)

When the actuator is in control mode, the stroke of 4.5 mm is achieved in approx. 2.7 min. A change of 1 mm stroke (warming up) can be achieved within approx. 30 s.

Depending on the setting of DIP switch 1 (see Setting the DIP switches), the continuous actuator can be used as 0...10 V (direction of operation 1) or 10...0 V (direction of operation 2). The control signal is then assigned linearly to the valve stroke. The integrated positioner controls the actuator according to positioning signal y. The continuous actuator positions the valve and, as soon as the position is reached, it stops.

When the plug module is connected, the actuator takes over the factory settings of the electrical zero point. The first position detection (calibration) is performed when the actuator reaches stand-by mode for the first time. Here the mechanical zero point and the position tolerances between the position panel and the coil on the printed circuit board are also taken into account. Thus the current position is set as the new zero point. Due to the accuracy of the sensor, an adjustment within the stroke range is not required. To compensate for a possible shift of the mechanical zero point due to ageing in the soft seal of the valve plug, an automatic recalibration is always performed when the actuator remains in stand-by mode for 17 min.

NC with direction of operation 1

DIP switch 1 is set to the “OFF” position. As the positioning signal increases, the actuator spindle moves in and opens the VUL or VUT 2-way valve with female thread or the control passage of the BUL 3-way valve with female thread. With the BXL 3-way valve with female thread, the control passage is closed and the mixing passage opened.

NC with direction of operation 2

DIP switch 1 is set to the “ON” position. As the positioning signal increases, the actuator spindle moves out and closes the VUL or VUT 2-way valve with female thread or the control passage of the BUL 3-way valve with female thread. With the BXL 3-way valve with female thread, the control passage is opened and the mixing passage closed.

DIP switch settings (NC and NO models)

Switch 1	OFF	0...10 V	Direction of operation 1
	ON	10...0 V	Direction of operation 2
Switch 2	OFF	Stroke 4.5 mm	
	ON	Stroke 3 mm	

Switch 3	OFF	Split-range unit off	
	ON	Split-range unit on	
Switch 4	OFF	0...4.5 V= 0...100%	Switches to 4.5...0 V= 0...100 % when switch 1 is ON
	ON	5.5...10 V= 0...100%	Switches to 10...5.5 V= 0...100 % when switch 1 is ON
Switch 3	OFF	2...10 V= 0...100%	Switches to 10...2 V= 0...100 % when switch 1 is ON
Switch 4	ON		

Definition of NC/NO

NC version "normally closed"

After the actuator is fitted, the VUL/BUL valves (or standard radiator valves) are closed in the idle state or without a control voltage. When the control voltage is applied to the actuator, the actuator spindle moves in and the valve spindle moves out, and the valve is opened.

Valve state with actuator without voltage: Closed

NO version "normally open"

After the actuator is fitted, the VUL/BUL valves (or standard radiator valves) are open in the idle state or without a control voltage. When the control voltage is applied to the actuator, the actuator spindle moves out and pushes the valve spindle, and the valve is closed.

Valve state with actuator without voltage: Open

Definition of the closing dimension

NC version "normally closed"

The closing dimension of a valve is the distance between the front surface of the spindle, pressed in with a preloading of < 100 N and the contact surface of the lower thread. The bayonet nut rests on this surface.

NO version "normally open"

The closing dimension of a valve is the distance between the front surface of the spindle when it is not pressed in and the contact surface of the lower thread. The bayonet nut rests on this surface.

Cross-section of the unit valve

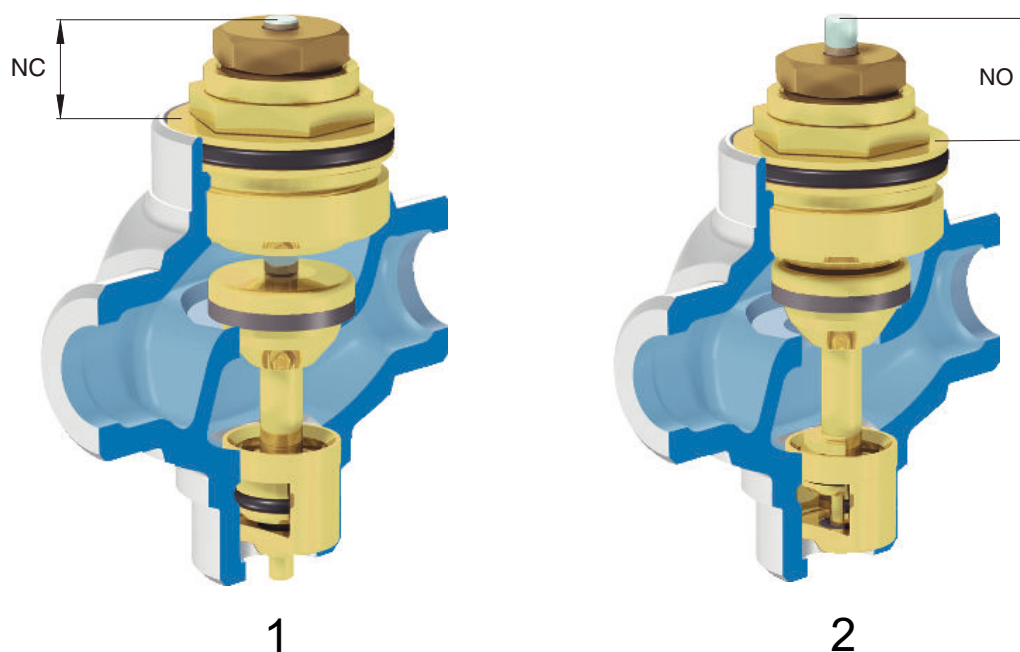

Fitting

The actuator is fitted to the valve based on the Low-Force-Locking technique (LFL). When the actuator is removed from the valve, the closing dimension and the preloading are released again. The condition as delivered ex works is restored and the actuator can be used again with full LFL functionality. First screw the bayonet nut onto the valve and tighten it to 2 Nm. Then put the actuator onto the valve without any force. The openings on the bayonet ring show the suitable fitting position with respect to the three ribs on the bayonet nut. Turn the bayonet ring in the clockwise direction through an angle of rotation of 90° until the first "click" - the valve plug is preloaded. After the second "click" the actuator is ready for operation. This position is also the security position against loosening due to vibrations.

While the bayonet ring is being turned, the actuator automatically adjusts to the closing dimension of the valve. As the zero point of the valve is defined mechanically and the tolerances of the valve are compensated, it is possible to operate multiple actuators in parallel.

To ensure problem-free operation with the NO actuator model, the compression spring in the valve must produce a force of $F_v \geq 30 \text{ N}$. The actuator must not be removed when it is warm, as otherwise when it is mounted on a valve again, the closing dimension will not be set correctly any more.

Closing dimension compensation

The closing dimension is compensated mechanically. While the bayonet ring is being turned, the compensation pin in the actuator is released, and the built-in spring uses a force of min. 105 N in the locked state (after the second "click") to press it onto the valve spindle. Thus the closing dimension is set between the compensation pin and a compensation casing and is fixed by gear teeth. The gear teeth are designed so that the compensation pin automatically slots into the next row of teeth below. This ensures that there is always preloading on the valve plug and the valve is sealed. Valves can become permeable due to ageing or a defective plug seal. In this case, the bayonet ring can be loosened easily and then turned in the clockwise direction until the second "click". The actuator has adjusted to the new closing dimension and the valve is sealed again. With the NO model, the compensation pin positions itself on the valve spindle without any force.

Closing dimension compensation with "normally closed" (NC)

When the standard bayonet nut supplied is used, the actuator can compensate a closing dimension of 8.5 mm to 13.5 mm.

Closing dimension compensation with "normally open" (NO)

When the standard bayonet nut supplied is used, the actuator can compensate a closing dimension of 12.5 mm to 17.5 mm.

Closing dimension compensation with raised bayonet nut (accessory)

The raised bayonet nut is used if the diameter of the bayonet ring on the actuator of 42.5 mm prevents the fitting (e.g. in angle valves, valves with measuring connection pieces or underfloor heating distributors). The standard closing dimension named above is achieved when the raised bayonet nut is combined with the N-insert (normal, black). When the raised bayonet nut is combined with the S-insert (reduced, white), the closing dimension is reduced by 5 mm. When the raised bayonet nut is combined with the valve without an insert, the closing dimension is increased by 5 mm.

Closing dimension range for various bayonet nuts

Bayonet nut	Raised	Standard	Raised	Raised
M30 × 1.5 (thread on valve neck)	Yes, black	Yes, black	Yes, black	Yes, black
M28 × 1.5 (thread on valve neck)	Yes, grey	Yes, grey	Yes, grey	Yes, grey
M30 × 1.0 (thread on valve neck)	Yes, white		Yes, white	Yes, white
N/S insert	S (reduced, white)	Not required	N (normal, black)	No insert
Closing dimension range NC (mm)	4.5...9.5	8.5...13.5	8.5...13.5	13.5...18.5
Closing dimension range NO (mm)	8.5...13.5	12.5...17.5	12.5...17.5	17.5...22.5

Position indicator

The cover is used as the biggest possible position indicator. It is clearly visible from all positions and can be felt in the dark.

With the "normally closed" (NC) model, the cover rises and the grey lifting part becomes visible. With a full lift, the cover is up to 5 mm above the top edge of the plug.

With the "normally open" (NO) model, the cover falls until it is level with the top edge of the plug. The grey lifting part is no longer visible.

Modular plug module; modifying types

The actuator gets its type function from the plug, i.e. the basic function of the basic device remains unchanged. This has a number of advantages, e.g. after it has been delivered and used, the actuator can be converted into a new device at a later point in time. All that is required is to put the new type plug on the bottom part of the housing and if necessary an accessory part on the lifting part.



Note

The voltage compatibility of the plug module with the related actuator must be checked before fitting.

The following modifications are possible:

- 2-point model with auxiliary contacts and vice versa
- 2-point model with continuous 0...10 V and vice versa, only with 24 V power supply
- Continuous 0...10 V model in auxiliary contacts (position panel must be removed first and replaced with switching cam)



Note

The model with auxiliary contacts cannot be converted to the continuous model due to the switching cam that cannot be removed.

The plug module can be removed from the actuator without a tool by pushing it by hand (up to approx. 30 N).

Engineering and fitting notes

When selecting the mains fuses, the start-up current of the heating element must be considered. To adhere to the specified technical data, the voltage loss due to the electric lines must not exceed 10 %.

Accessories

Removal protection

The removal protection consists of two half-shells that are fitted around the actuator. When these half-shells are closed, they can only be removed by destroying them. The removal protection prevents the actuator from being removed from the valve, the electric plug from being removed and the DIP switch from being adjusted. The position indicator remains easy to see and touch.

Connection diagram

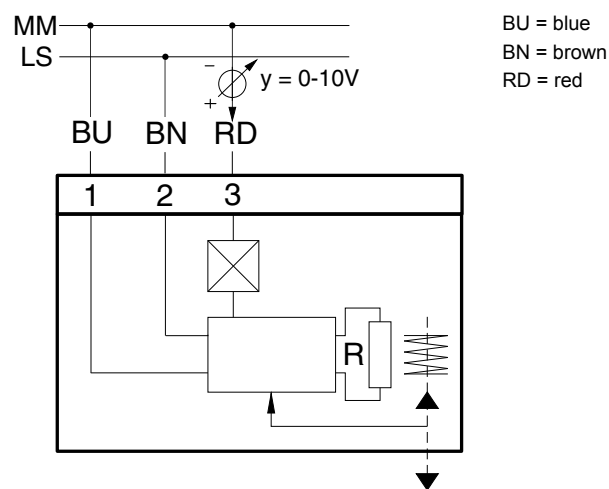

Dimension drawing

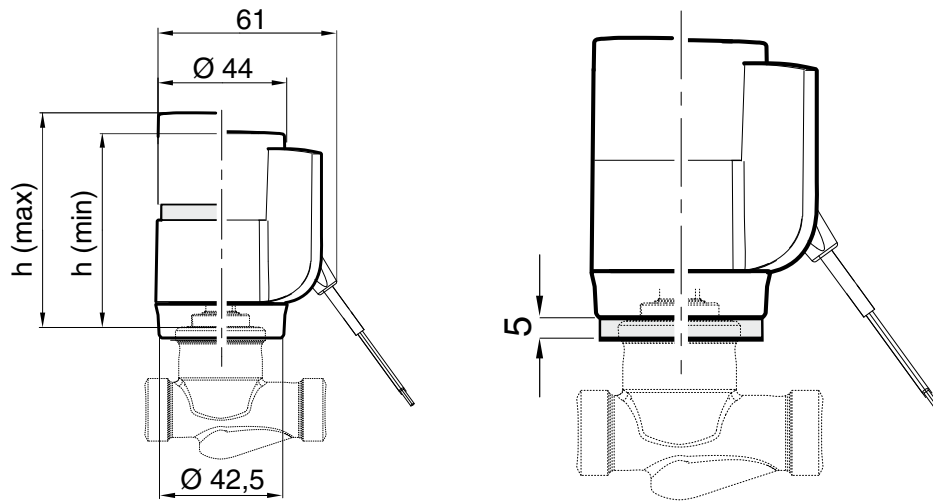

Accessory 0550390*01

	h (min.)	h (max.)
NC	59	66
NO	59	64
●	66.5	73.5