

BUS: 3-way flanged valve, PN 40 (pn.)

How energy efficiency is improved

Efficiency means precise and reliable control

Features

- Continuous control of cold/warm/hot water in closed circuits
- Assembly with AVP 242 to 244 actuators as control unit
- Water quality as per VDI 2035
- Valve with flange connection as per EN 1092-2, seal form B
- Regulating valve, free of silicone grease, matt black
- Not suitable for drinking water or potentially explosive atmospheres
- The valve is closed when the spindle is moved out
- For use only as a control valve
- Valve body made of cast steel
- Stainless-steel seat and plug
- Stainless-steel spindle
- Maintenance-free stuffing box, made of stainless steel, with spring-loaded PTFE washer up to 220 °C, with graphite seal up to 260 °C



BUS025F205

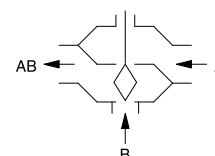

Technical data

Parameters

Nominal pressure	PN 40
Connection	Flange as per EN 1092-2, form B
Valve characteristic, mixing passage	Linear
Control ratio	> 50 : 1
Leakage rate of control passage	≤ 0.05% of k_{VS} value
Leakage rate, mixing passage	≤ 1.0% of k_{VS} value

Ambient conditions

Operating temperature ¹⁾	-10...240 °C
Operating pressure	40 bar at -10...50 °C 36.3 bar at 120 °C 29.4 bar at 220 °C 27.8 bar at 260 °C

Standards and directives

Pressure and temperature data	EN 764, EN 1333
Flow parameters	EN 60534

Overview of types

Type	Nominal diameter	k_{VS} value	Valve characteristic, control passage	Valve stroke	Weight
BUS015F225	DN 15	1.6 m³/h	linear	20 mm	7.2 kg
BUS015F215	DN 15	2.5 m³/h	linear	20 mm	7.2 kg
BUS015F205	DN 15	4 m³/h	linear	20 mm	7.2 kg
BUS020F205	DN 20	6.3 m³/h	linear	20 mm	8.4 kg
BUS025F205	DN 25	10 m³/h	linear	20 mm	9.4 kg
BUS032F205	DN 32	16 m³/h	linear	20 mm	12.4 kg
BUS040F205	DN 40	25 m³/h	linear	20 mm	15.5 kg
BUS050F205	DN 50	40 m³/h	linear	20 mm	19.2 kg
BUS065F205	DN 65	63 m³/h	linear	30 mm	27.6 kg
BUS080F205	DN 80	100 m³/h	linear	30 mm	36.5 kg
BUS100F205	DN 100	160 m³/h	linear	30 mm	61.2 kg

¹⁾ No stuffing box heater required down to -10 °C. At temperatures below -10 °C and down to -60 °C, use special version with bellows-type mechanical seal (available on request). Application: Water with anti-freeze (glycol up to 55% and brine solution), max. operating pressure 30 bar. Above 130 °C or 180 °C, use the relevant adaptor (accessory). Above 220 °C and up to 260 °C, use stuffing box with graphite seal (accessory)



Type	Nominal diameter	k_{VS} value	Valve characteris- tic, control pas- sage	Valve stroke	Weight
BUS125F305	DN 125	220 m ³ /h	equal-percentage	40 mm	82.5 kg
BUS150F305	DN 150	320 m ³ /h	equal-percentage	40 mm	113.5 kg

Accessories

Type	Description
0372336180	Adaptor (required when temperature of the medium is 130...180 °C)
0372336240	Adaptor (required when temperature of the medium is 180...260 °C)
0378373001	Stuffing box with graphite seal for temperatures of 220...260 °C; DN 15...50
0378373002	Stuffing box with graphite seal for temperatures of 220...260 °C; DN 65...100
0378373003	Stuffing box with graphite seal for temperatures of 220...260 °C; DN 125...150

Combination of BUS with pneumatic actuator

- i** *Warranty: The technical data and pressure differences indicated here are applicable only in combination with SAUTER valve actuators. The warranty does not apply if used with valve actuators from other manufacturers.*
- i** **Definition of Δp_s :** Maximum admissible pressure drop in the event of a malfunction (pipe break after the valve) at which the actuator reliably closes the valve by means of a return spring.
- i** **Definition of Δp_{max} :** Maximum admissible pressure drop in control mode at which the actuator reliably opens and closes the valve.
- i** *The running time is based on the centair air flow rate (400 l_r/h) and on a supply line with a length of 20 m and a diameter of 4 mm.*

Pressure differences

Actuator	AVP242F021	AVP243F021	AVP244F021	AVP243F031	AVP244F031
Admissible pressure p_{stat}	≤ 32 bar	≤ 40 bar	≤ 40 bar	≤ 25 bar	≤ 40 bar
Running time	8 s	24 s	40 s	24 s	40 s

Δp [bar]

As control valve	Δp_{max}	Δp_s	Δp_{max}	Δp_s	Δp_{max}	Δp_s	Δp_{max}	Δp_s	Δp_{max}	Δp_s
BUS015F225										
BUS015F215	12.1	15.6	21.1	21.7	24.5	24.5	–	–	–	–
BUS015F205										
BUS020F205	7.7	15.6	13.5	21.7	17.5	17.5	–	–	–	–
BUS025F205	6.6	9.4	11.6	13.1	14.7	14.7	–	–	–	–
BUS032F205	4.7	7.2	8.3	9.9	10.4	10.4	–	–	–	–
BUS040F205	3.0	4.1	5.3	5.7	6.2	6.2	–	–	–	–
BUS050F205	1.9	2.6	3.4	3.7	3.9	3.9	–	–	–	–
BUS065F205	–	–	–	–	–	–	1.7	2.2	4.4	4.4
BUS080F205	–	–	–	–	–	–	1.1	1.5	2.9	2.9
BUS100F205	–	–	–	–	–	–	0.7	0.9	1.9	1.9
BUS125F305	–	–	–	–	–	–	0.4	0.7	1.3	1.3
BUS150F305	–	–	–	–	–	–	0.3	0.5	1.0	1.0

Cannot be used as distribution valve

 At temperatures above 130 °C, accessories are required

Pressure-stroke characteristics (with valve attached)

N15...50:

Characteristic not adjustable

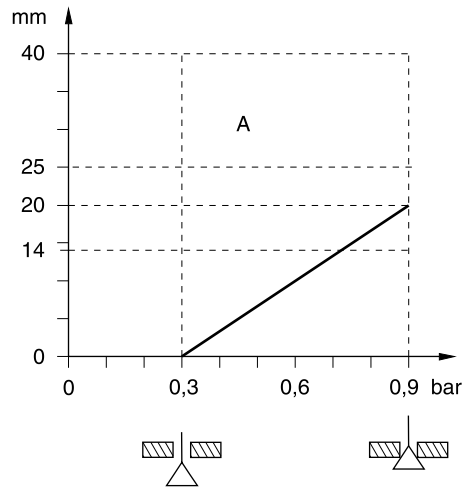
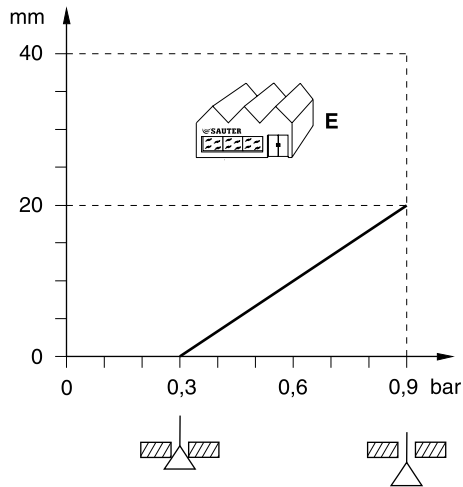

DN65...150:

Adjustable characteristic

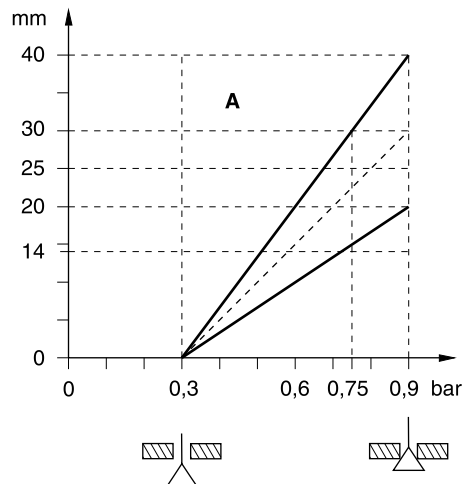
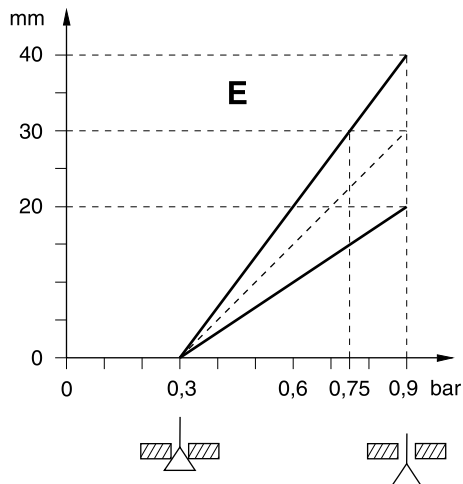

Description of operation

The valve can be moved to any intermediate position with an electric actuator. When the spindle is moved out, the control passage of the valve is closed. These valves may only be used as control valves. Observe the direction of flow shown on the valve. The flow parameters correspond to EN 60534.

Used as a control valve

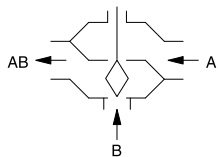

These control valves are characterised by their reliability and precision and make an important contribution towards efficient regulation. They meet challenges such as spring-controlled closing functions, overcoming great differential pressures, controlling medium temperatures and performing the shut-off function, all in a low-noise form.

The valve spindle is automatically and firmly connected to the actuator spindle. The stainless steel plug controls the linear or equal-percentage flow rate in the control passage. The tightness of the valve is ensured by the stainless steel ring pressed in both seats and the corresponding plug. The stuffing box is maintenance-free. This consists of tapered PTFE rings and a spring. The spring ensures permanent tension on the seals, thus guaranteeing that they are leaktight against the spin-

dle. In addition, a grease reserve ensures that the spindle is constantly lubricated. The grease reserve also stops particles that are present in the medium from penetrating to the PTFE seal.

Intended use

This product is only suitable for the purpose intended by the manufacturer, as described in the "Description of operation" section.

All related product documents must also be adhered to. Changing or converting the product is not admissible.

Engineering and fitting notes

The valves are combined with the AVP 242, 243 and 244 pneumatic actuators. The actuator is mounted directly on the valve and fastened with screws. The actuator is automatically connected to the spindle by applying compressed air to the pneumatic actuator. The connector automatically closes the connection to the valve as soon as it reaches the lower valve seat.

Additional technical data

SAUTER slide rule for valve sizing	P100013496
Technical manual on control units	7 000477 001
Parameters, fitting notes, control, general information	Applicable EN, DIN, AD, TRD and UVV regulations
CE conformity as per PED 97/23/EC (fluid group II) BUS 015...150: CE-0525 label	Category II
Fitting instructions:	
BUS	MV 506071
AVP 242	MV 506012
AVP 243/244	MV 506013
Declaration on materials and the environment	MD 76.126

Fitting position

The control unit can be fitted in any position, but the hanging position is not recommended. Condensate, drops of water, etc. must be prevented from entering the actuator. With horizontal installation and no structural support for the actuator, the maximum admissible weight on the valve is 25 kg.

At a medium temperature

- **Up to 130 °C:**
 - In any position except suspended.
- **Over 130 °C:**
 - At temperatures of over 130 °C or over 180 °C, a horizontal fitting position is recommended, and the appropriate adaptor for the temperature must be used. The adaptor can also be used as an extension to come out of the pipe insulation with the actuator. To protect the actuator from excessive heat, the piping must be insulated.

When the actuator is mounted on the valve, make sure the plug is not twisted on the stainless steel seat (this can damage the sealing surface). When insulating the valve, it may only be insulated up to the connecting clip of the actuator.

Outdoor installation

We recommend protecting the devices from the weather if they are installed outside buildings.

Using with water

So that impurities are retained in the water (welding beads, rust particles, etc.) and the spindle seal is not damaged, we recommend installing collecting filters, for example one for each floor or pipe run. Water requirements according to VDI 2035.

When using an additive in the water, the compatibility of the valve materials must be checked with the manufacturer of the medium. The materials table shown below may be used. When using glycol we recommend a concentration between 20% and 55%. These valves are not suitable for drinking water or potentially explosive atmospheres.

Other information regarding hydraulics and noise in systems

The valves can be used in a low-noise environment. To prevent noise, the pressure differences Δp_{\max} listed below should not be exceeded. These are listed as recommended values in the table of pressure losses.

The pressure difference Δp_v is the maximum pressure that may act on the valve regardless of the stroke position, in order that the risk of cavitation and erosion is limited. These values are irrespective

of the actuator force. Cavitation accelerates wear and causes noises. To prevent cavitation, which mainly occurs in applications with water or steam, the differential pressure Δp_{max} should not exceed the Δp_{krit} value:

$$\Delta p_{krit} = (p_1 - p_v) \times 0.5$$

p_1 = upstream pressure in front of the valve (bar)

p_v = steam pressure

It is calculated using absolute pressure.

BUS flow-rate chart

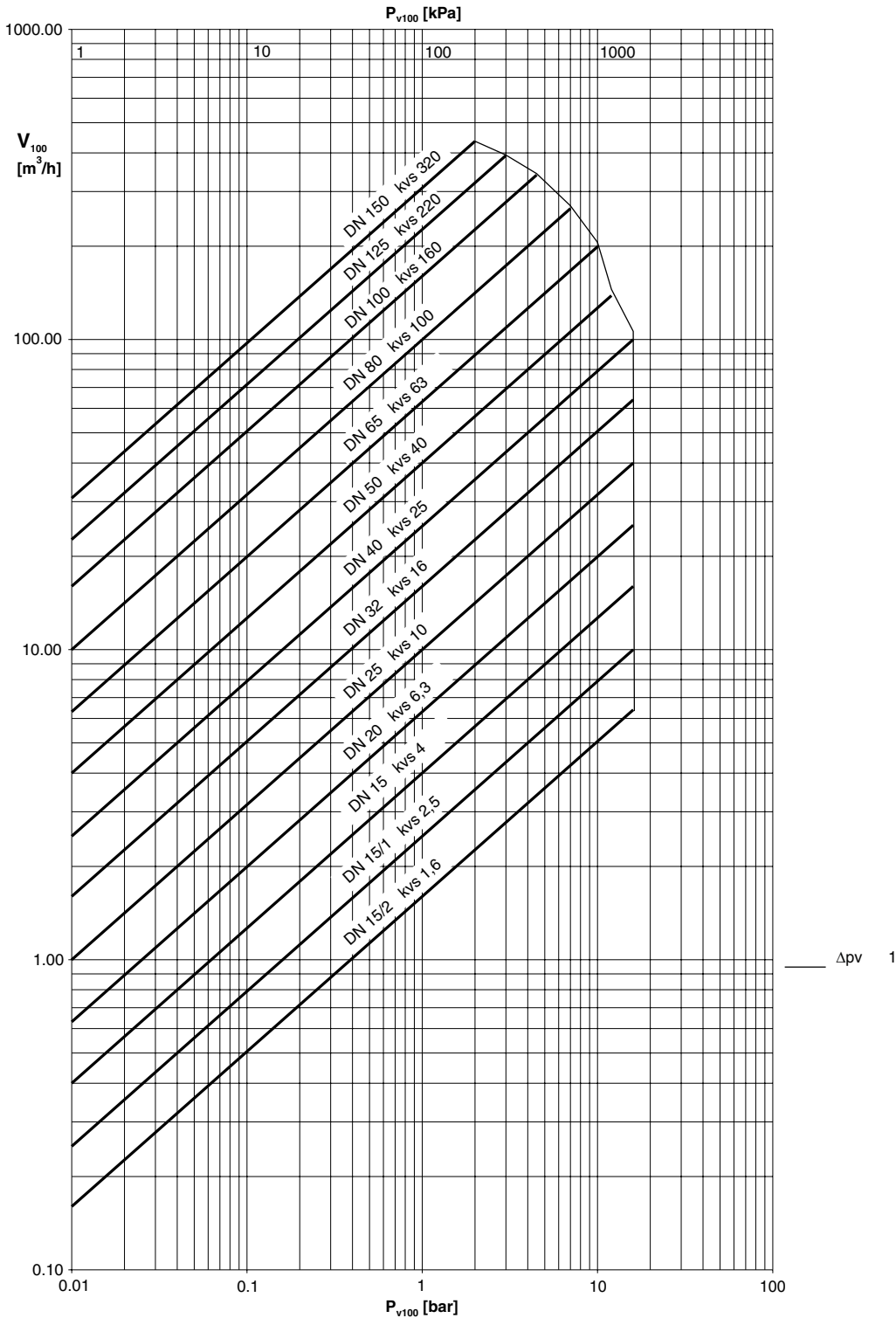

Type	Δp_v	
	Used as control valve [bar]	Used as distribution valve [bar]
BUS015F225	40	-
BUS015F215	40	-
BUS015F205	40	-
BUS020F205	40	-
BUS025F205	40	-
BUS032F205	40	-
BUS040F205	40	-
BUS050F205	30	-
BUS065F205	30	-
BUS080F205	25	-
BUS100F205	25	-
BUS125F305	15	-
BUS150F305	15	-

Additional version information

Valve body made of cast steel as per EN 10213, code GP240GH+N, material number 1.0619+N with smooth drilled flanges as per EN 1092-1, seal form B. Valve body protected by matt paint RAL 9005 black. Recommended for the welding flange as per EN 1092-1. Valve fitting length as per EN 558-1, basic series 1. Flat seal on valve body made of asbestos-free material.

PTFE collar and sealing ring for stuffing box available as spare part no. 0378372

Material numbers as per DIN

	DIN material no.	DIN designation
Valve body	1.0619+N	GP240GH+N
Valve seat	1.4021	X20Cr13
Spindle	1.4021	X20Cr13
Plug	1.4021	X20Cr13
Stuffing box	1.4021	X20Cr13
Seal under stuffing box	Cu	DIN 7603

Additional details on the definitions of pressure difference

Δp_v :

Maximum admissible pressure difference over the valve in each stroke position, limited by noise level and erosion.

This parameter characterises the valve as a flow element with specific hydraulic behaviour. Monitoring the cavitation and erosion along with the associated noise increases the service life and the operational capacity.

Δp_{max} :

Maximum admissible pressure difference over the valve at which the actuator can reliably open and close the valve.

This takes account of: Static pressure and flow effects. This value ensures trouble-free stroke movement and closing of the valve. The value Δp_v of the valve is never exceeded.

Δp_s :

Maximum admissible pressure difference over the valve in the event of a malfunction (e.g. power failure, excessive temperature or pressure, pipe break) at which the actuator can close the valve tightly and, if necessary, maintain the entire operating pressure against atmospheric pressure. Because this is a quick-closing function with a rapid stroke movement, Δp_s can be greater than Δp_{max} or Δp_v . The disruptive flow effects that arise here are quickly passed through and are of minor importance in this mode.

For 3-way valves, the values only apply to the control passage.

Δp_{stat} :

Line pressure behind the valve. This essentially corresponds to the idle pressure when the pump is switched off, caused for example by the fluid level in the system, increased pressure due to pressure tanks, steam pressure, etc.

Disposal

When disposing of the product, observe the currently applicable local laws.
 More information on materials can be found in the Declaration on materials and the environment for this product.

Dimension drawings

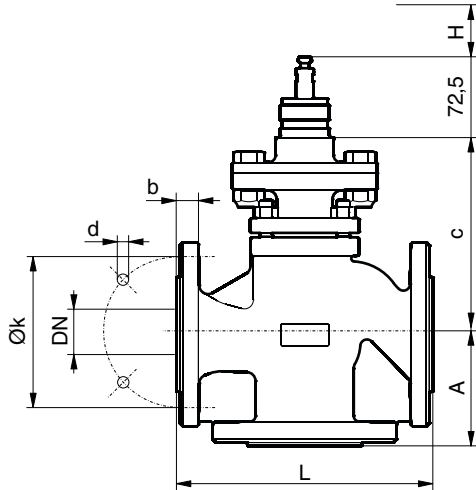

BUS	DN	A	c	L	H	k	d	b
015	15	65	143	130	20	65	14 x 4	16
020	20	70	143	150	20	75	14 x 4	18
025	25	75	147	160	20	85	14 x 4	18
032	32	80	173	180	20	100	19 x 4	18
040	40	90	179	200	20	110	19 x 4	18
050	50	100	177	230	20	125	19 x 4	20
065	65	120	213	290	30	145	19 x 8	22
080	80	130	229	310	30	160	19 x 8	24
100	100	150	248	350	30	190	23 x 8	24
125	125	200	295	400	40	220	28 x 8	26
150	150	210	357	480	40	250	28 x 8	28

M10462a

AVP 242

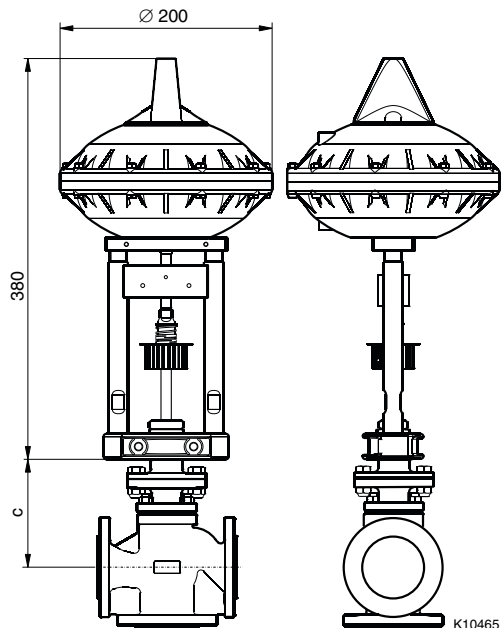

AVP 243, 244

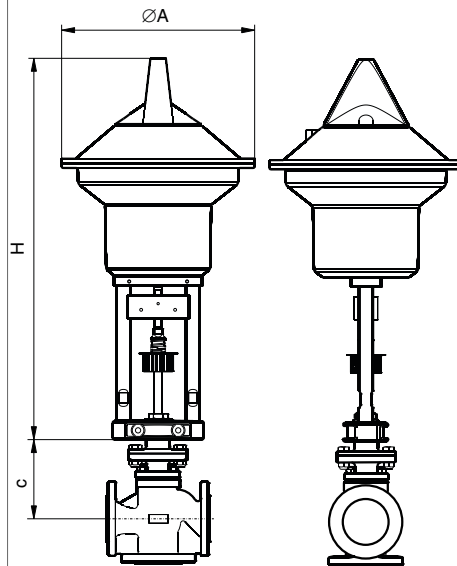

AVP ...	A	H
243 F021	250	497
243 F031	250	517
244 F021	335	536
244 F031	335	556

K10466

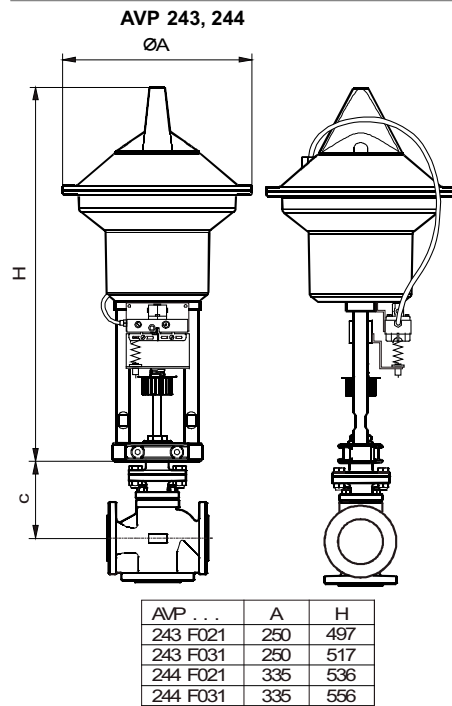

Accessories

0372336 180
0372336 240

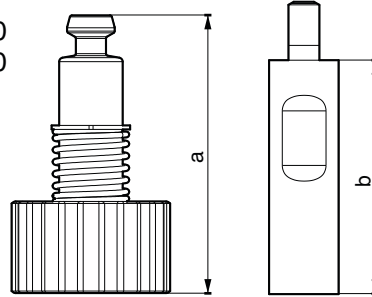

0372336	T (°C)	a (mm)	b (mm)
180	180	69,4	60
240	240	109,4	100